

CONTAINER VALVE BE 50/BE 80



Container valve BE 50 with drain bolt lock.

TECHNICAL DATA

Nominal diameter:	DN 50/ DN 80
Face-to-face:	EBRO works standard
Flange accommodation:	according to the connections container building
Flange Surface Design:	EN 1092, Form A/B, ASME RF, FF
Marking:	EN 19
Tightness check:	EN 12266 (Leakage rate A) ISO 5208, Category 3
Temperature range:	-20°C to +160°C (depending on pressure and medium)
Operating pressure:	max. 4 bar
Body:	Aluminium alloy GD-AISI9Cu3 (3.2163)
Seat:	PTFE
Disc:	Stainless Steel G-X6CrNiMo18-10 (1.4408)

FEATURES

- Shut-off valve for lugging under containers
- Aluminium body and EN JS 1030
- Multiple shaft bearing
- Maintenance-free
- Can be disassembled, material-specific recycling possible

GENERAL APPLICATIONS

- Container building
- Silos
- Hazardous freight container for varnishes, colours, solvents, resins



Container valve BE 80 with OPEN/ CLOSE lever.

CONTAINER VALVE BE 50/BE 80

BE 50 WITH DRAIN BOLT LOCK

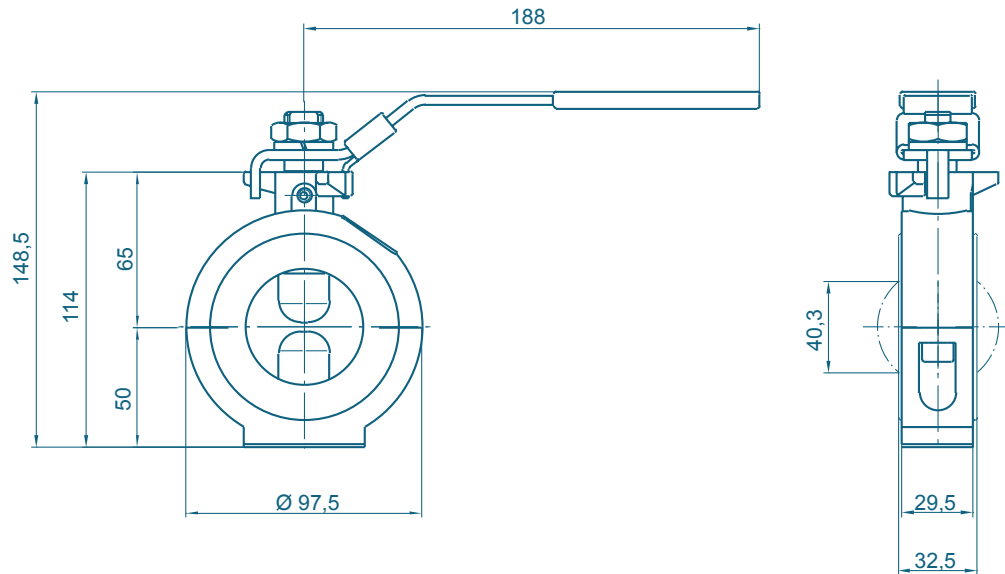

Weight: 0,95 kg

BE 80 WITH HAND LEVER

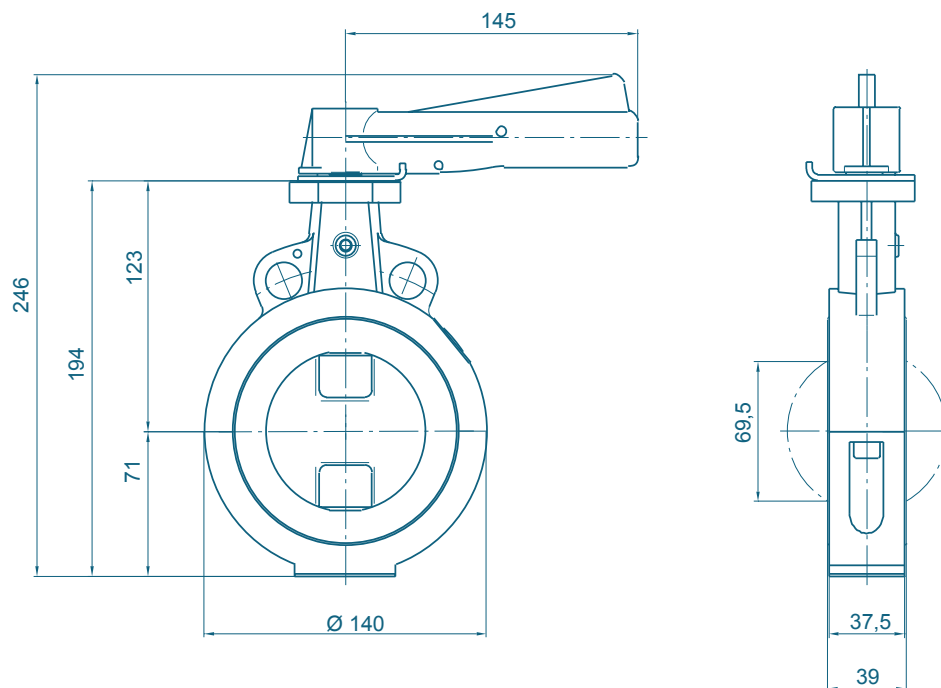

Weight: 2,05 kg

Subject to change without notice